

Samuel Freeman

Property-Owning Democracy and the Difference Principle*

Abstract: John Rawls says: “The main problem of distributive justice is the choice of a social system.” Property-owning democracy is the social system that Rawls thought best realized the requirements of his principles of justice. This article discusses Rawls’s conception of property-owning democracy and how it is related to his difference principle. I explain why Rawls thought that welfare-state capitalism could not fulfill his principles; it is mainly because of the connection he perceived between capitalism and utilitarianism.

1. Introduction: The Choice of a Social System

John Rawls says: “The main problem of distributive justice is the choice of a social system.” (Rawls 1971, 274; 1999a, 242) Discussions of distributive justice normally are narrowly focused on the distribution of income and wealth—whether equally, or according to effort, contribution, need, utility, etc. Rawls transforms this narrow understanding of distributive justice into a complex enquiry regarding the organization of productive relations among democratic citizens, including their ownership and control of productive resources, and distribution of economic powers and responsibilities as well as income and wealth.

Rawls says the difference principle is not a “micro” or “allocative principle” that applies directly to “small-scale situations” to divide up preexisting sums of income and wealth. Rather, it is a “macro principle” for organizing economies and “for ranking social forms viewed as closed systems” (Rawls 1999a, 229). The point here is not simply that the difference principle applies to “the basic structure of society” to specify a “social process” by which distributive claims are determined by “pure procedural justice”. Rawls is often accused of endorsing “the severe inequalities” typical of capitalism (Cohen 2008, 138). According to G. A. Cohen, because it applies to institutions rather than directly to assess individual entitlements and conduct, Rawls’s difference principle justifies the practices of

* I appreciate comments from participants at the conference on property-owning democracy at the University of Zurich; also comments from participants at a conference on Rawls sponsored by Centro Einaudi in Turin, Italy; participants at the NYU Political Philosophy seminar in May 2012; and members of the audience at a Rawls symposium at the 2012 APA Eastern Division Meetings in Atlanta.

‘high flying’ Wall Street ‘buccaneers’ that may improve the least advantaged position but also result in vast inequalities typical of capitalism.

Cohen’s objection assumes that the difference principle narrowly applies to existing institutions within a capitalist society and authorizes piecemeal changes in the status quo to benefit the least advantaged, no matter how much inequality results. There are two problems with this assumption. First, there is a limit to the degree of inequality allowable by the difference principle. Rawls says that the difference principle cannot be taken seriously apart from its setting within prior principles and that “[t]he requirements of the prior principles have important distributive effects” (Rawls 2001, 46, n. 10). The principles of equal basic liberties and fair equal opportunities restrict permissible inequalities of income and wealth that might otherwise be allowed by the difference principle. Moreover, in saying that the problem of distributive justice is the ‘choice of a social system’ Rawls means that the principles of justice impose a broad systemic requirement on the economy. Societies are to take comprehensive measures to put into place the economic system that makes the least advantaged members better off than they would be under any other economic system, (consistent with prior principles). This broad requirement contrasts markedly with Cohen’s narrow interpretation of the difference principle, which says that it authorizes most any measure that alters the status quo in a capitalist society so long as it improves the position of the least advantaged. Only when society’s basic structure *already* satisfies the systemic requirement and the least advantaged are better off than in any alternative system, is it appropriate to apply the difference principle in the piecemeal fashion envisioned by Cohen’s objection, to make marginal improvements to the position of the least advantaged.

The broad interpretation of the difference principle leaves open many practical questions about its application to non-ideal circumstances like our own. These are complex issues, but clearly the difference principle does not under non-ideal circumstances justify just any measures that (maximally) benefit the least advantaged in the short run, when that closes off future options that bring about the appropriate social systems under which the difference principle ideally applies. Thus measures that benefit the least advantaged while cementing and exacerbating the already existing severe inequalities in our capitalist system violate the difference principle (as well as the first principle and FEO) since they take the wrong path to reform. Such measures make it more difficult to reform fundamentally unjust background institutions and take effective measures towards approximating a social system that maximally benefits the least advantaged.

Rawls argues that, correctly applied to the choice of a social system, the principles of justice do not justify any form of capitalism. The two economic systems that meet these principles’ requirements are property-owning democracy and liberal socialism. Since neither is capitalist, and both limit inequalities and broadly disseminate ownership and control of productive capital, high-flying Wall Street buccaneers and other sources of capitalist inequalities will not exist in these societies.

2. Capitalism, Socialism, and Property Owning Democracy

Rawls says in the Preface to the revised edition of *A Theory of Justice* that one of the revisions he would make were he to write the book again is that he does not sharply distinguish between property-owning democracy and the welfare state.¹ In *Justice as Fairness: A Restatement* (Rawls 2001) he explains this distinction. He interprets property-owning democracy and welfare state capitalism in terms of the degree to which they embody the main features of his principles of justice. A property-owning democracy (POD) he characterizes as a democratic society in which land and capital are privately owned and widely (though not equally) held. Concentrations of wealth have been dissolved or mitigated so that “[s]ociety is not so divided that one fairly small sector controls the preponderance of productive resources”. With the wide dispersion of property in income and wealth, there are no longer distortions of democratic government typical of capitalist democracies. Rawls says, “[w]hen this is achieved and distributive shares satisfy the principles of justice, many socialist criticisms of the market economy are met” (Rawls 1971, 280).

Rawls’s advocacy of POD parallels his response to socialist arguments against markets and capitalism. In *Restatement*, §52, “Addressing Marx’s Critiques of Liberalism”, Rawls contends that a POD informed by the principles of justice would permit all citizens “a right in property in productive assets”; “give adequate protections to the positive liberties”; largely overcome “the demeaning features of the division” of labor; and assure all “a fair opportunity to exert political influence”. Moreover since POD provides for both worker-managed firms and “greater democracy within capitalist firms”, it addresses Marx’s concern for democracy in the workplace and in shaping the general course of the economy (Rawls 2001, 177–8).

In distinguishing property-owning democracy from welfare-state capitalism, Rawls depicts capitalism as a particular kind of private property market system. Like Marx, Rawls sees capitalism as a social and political as well as an economic system. Private ownership and control of means of production are largely concentrated in the hands of a privileged minority. Consequently there are large inequalities, not only in the distribution of income, wealth and economic powers and positions of responsibility, but also in the exercise of effective political powers and social prerogatives, and in access to social and economic opportunities. This privileged class exercises a preponderance of political power, and capitalists’ wealth and social and economic powers put them in a strategic position to exert a dominant influence over the political agenda. Unlike Marx, Rawls does not see open class conflict as an inevitable feature of capitalism, but he does think there are structural conflicts of interest normally decided in favor of the most advantaged.

¹ Rawls 1999a, xiv. Rawls uses the term ‘property-owning democracy’ but five times in the original edition of *A Theory of Justice* (Rawls 1971, 78, 274, 279) he does not mention the welfare state or welfare state capitalism at all.

Rawls distinguishes between *laissez-faire* and welfare state capitalism. He regards these and other economic systems he compares—property-owning democracy, liberal socialism, and state socialism—as “ideal institutional descriptions” approximated by real world societies. When working well, he says, social institutions meet the “public aims and principles of design” of these idealized societies (Rawls 2001, 137). Rawls elaborates the primary features of these economic systems, discussing the degree to which they approximate or depart from his own principles of justice.

Laissez-faire capitalism strongly resembles the position Rawls calls “the system of natural liberty” (Rawls 1999a, 57). *Laissez faire* constitutionally guarantees certain personal liberties, such as freedom of conscience and association, together with extensive economic rights, including private ownership and control of the means of production and full freedom of economic contract. *Laissez-faire* also guarantees formal equality of opportunity, which bars government-imposed discrimination in awarding educational and employment opportunities on grounds of race, religion, gender, etc. But there is no prohibition of private discrimination in education and employment, nor guaranteed rights to publicly funded education or health care. Finally, *laissez-faire* recognizes government’s duty to provide certain public goods (highways, canals, etc.); to maintain the efficiency of markets (by preventing price fixing and regulating monopolies); and to guarantee a ‘rather low’ social minimum (for the disabled, orphans, etc.).² Otherwise income and wealth are distributed according to competitive market relations, or by gift, bequest, and other voluntary transfers.

Though *laissez-faire* still has many advocates (especially in the U.S.), welfare state capitalism now has become the norm in democratic capitalist societies. Unlike *laissez faire*, welfare state capitalism does not constitutionally guarantee extensive private economic liberties; instead, property and contract rights are regulated and restrained for the public good, including economic efficiency, promoting the general welfare, and providing a social minimum. Welfare state capitalism achieves some degree of fair equality of opportunity (Rawls 1999a, xv), mainly by providing a publicly funded universal education system and prohibiting private discrimination on grounds of race, ethnicity, religion, and gender in education and employment. Finally welfare state capitalism guarantees a sizable social minimum that includes old-age pensions, unemployment benefits, welfare payments to meet basic needs, and universal health care.

By ‘socialism’ Rawls means an economy with public ownership of the means of production. ‘State socialism’ involves a command economy and state planning. In ‘liberal socialism’, economic power is decentralized and markets allocate productive resources, including labor. Publicly owned capital is leased to worker-managed and controlled firms at a market rate of interest. Democratic decisions under the constitution determine general features of the economy, such as the rate of savings, the portion of the social product to be devoted to public goods, and the direction of certain investments (Rawls 1999a, 248).

² In these three, and other, respects *laissez-faire* capitalism differs from Nozick’s libertarianism, which rejects public goods, a social minimum, and contract restrictions.

In defining socialism institutionally, in terms of public ownership, Rawls's understanding differs from recent discussions that associate socialism with economic egalitarianism (G. A. Cohen, John Roemer, etc.) In Roemer's so called 'coupon socialism', government provides all citizens with coupons to purchase stock in firms and/or mutual funds they choose, and they receive income from profits in the form of dividends, with rights to trade for shares in other firms/funds, but not to sell their shares or transfer ownership interest to others by gift or bequest (Roemer 1994). Whether this form of ownership is to be regarded as public, private, or a hybrid, it meets a primary aspiration of property-owning democracy: to break up concentrations of private capital and disperse ownership, or at least rights to profits, widely among citizens.

Regarding socialism, Rawls suggests that public ownership is independent of how much of society's wealth is devoted to public goods (Rawls 1999a, 235). The same would apply to social welfare programs. Like laissez-faire capitalism, a socialist society (such as China) may choose to provide little in the way of social welfare benefits and other public goods (e.g. public health, a clean environment, parks, etc.), and instead impose a high rate of savings and reinvestment of its productive wealth to further build up society's capital. This suggests that Rawls need not conceive of the welfare state as being peculiar to capitalism; one could as well speak of 'welfare state socialism' in contrast to other socialisms that are not as concerned with maintaining the individual welfare of all its members.

3. Ideal Institutional Designs

In his discussion of property-owning democracy, Rawls discusses the five 'ideal' institutional arrangements: laissez faire capitalism, welfare state capitalism, state socialism, liberal socialism, and property-owning democracy. The first three he argues violate the principles of justice in several ways (Rawls 2001, 137–38).

Laissez-faire capitalism infringes upon three main provisions of Rawls's principles: first, even when it provides formal equality of political rights, laissez faire does not guarantee the fair value of the political liberties. Moreover it insures formal but not fair equality of opportunity. Finally, since laissez-faire primarily aims for economic efficiency, its social minimum, when it exists, is fixed 'rather low'.

Rawls says that while *welfare state capitalism* mitigates many inequalities of laissez-faire, it still allows for great inequalities in ownership of productive resources; consequently "the control of the economy and much of political life rests in few hands". As a result, it fails to guarantee the fair value of the political liberties and does not fully achieve fair equality of opportunity. Finally, even though welfare provisions and the social minimum may be quite generous, "a principle of reciprocity to regulate economic and social inequalities is not recognized" (Rawls 2001, 138).

State socialism with a command economy and one-party rule are said to violate the basic liberties, including equal political liberties and their fair value.

Rawls suggests in *Theory* that freedom of occupation and choice of workplace and careers (among the rights securing integrity and freedom of the person) are jeopardized in a command economy (Rawls 1999a, 241). Not much more is said about state socialism, except that it uses markets, if at all, only for purposes of rationing consumer goods.

Rawls contends that only *property-owning democracy* and *liberal socialism* realize his two principles of justice. Both provide for institutions that guarantee the fair value of the political liberties. Here Rawls mentions four institutions: publicly funded campaigns; restrictions on contributions to candidates; assurance of an even access to public media; time, place and manner regulations of speech and the press during campaigns. These and other measures are to achieve “fair and equal access to the political process as a public facility”, and prevent the more advantaged from dominating the “the limited space of the public political forum” (Rawls 2001, 149–50). Also both POD and liberal socialism, unlike WSC, conceive of political democracy as deliberative, involving public reasoning on the common good. Democracy is then more than a procedural mechanism for satisfying the greater sum of interests, or a majoritarian competition among conflicting interests, which Rawls sees as typical of capitalist democracies. POD and liberal socialism endorse constitutional limits on majority rule that protect ‘constitutional essentials’, including the basic liberties, equality of opportunity, and a “social minimum providing for the basic needs of all citizens” (Rawls 2001, 48). Rawls says that the first principle requires that inheritance and income are to be taxed at progressive rates, and property rights are to be specified “to secure the institutions of equal liberty in a property-owning democracy and the fair value of the rights they establish” (Rawls 1971, 279). This suggests that, to achieve and maintain the fair value of the political liberties, it may be necessary to reduce inequalities of income and wealth, and modify ownership of property, more than the difference principle requires. Rawls from early on envisioned the basic liberties as having significant distributive effects.

Next, to meet fair equality of opportunity, both POD and liberal socialism provide for extensive universal educational benefits and job training, child care allowances for working parents, as well as universal health care,—which may also be provided by WSC. But unlike the welfare state, in POD estate and inheritance taxes widely redistribute individuals’ assets upon death, to break up concentrations of wealth. In *Theory*, Rawls suggests that steeply progressive income and wealth taxes might be necessary “to forestall accumulations of property and power likely to undermine the corresponding institutions” that maintain both FEO and the basic liberties (Rawls 1971, 279). Rawls also says that it is the duty of governments to bring about reasonably full employment so that those who want work can find it. This notably includes government assuming responsibility for being the “employer of last resort” (Rawls 1999c, 50).

Finally, in property-owning democracy the economic system is organized to achieve reciprocity among free and equal persons rather than maximum efficiency or aggregate wealth or welfare. Unlike WSC this requires a more equal distribution of income and wealth and a greater social minimum that goes beyond meeting the basic needs of the least advantaged. Rawls mentions here

“graded income supplements (a so-called negative income tax)” and “family allowances” which add to the market income the less advantaged receive from their work (Rawls 1999a, 243). Also, POD seeks the widespread distribution of *productive wealth*, as well as economic powers and positions of responsibility among those actively engaged in production. Here Rawls says POD encourages either worker-owned and managed firms or cooperatives (Rawls 2001, 176, 178), or “share economy” arrangements with workers’ partial ownership of firms with rights to share in profits (Rawls 2001, 72). Finally though he says there is no basic right that workers own and control the means of production, Rawls mentions “the importance of democracy in the workplace and in shaping the general course of the economy” (Rawls 2001, 114, 178). Given these and other claims, property-owning democracy for Rawls seems to include some degree of worker prerogatives and responsibilities if not worker control, as well as workers’ participation in firms’ governance, such as rights to vote for management and have representatives on boards that make major decisions (such as *Mitbestimmung* or Co-determination rights).³

Rawls did not say anything further about the institutions of a POD informed by the principles of justice. It would seem open to him to endorse a wide range of measures, such as substantial initial property endowments for all citizens (Ackerman, Dworkin), widespread dispersal of stock ownership and firms’ profits among all citizens (Roemer), and limits on inheritance of wealth that equalize starting positions enough to insure that people could not live too comfortably without working (Meade).⁴ Rawls seems to have had a rather flexible conception of POD, allowing for mixed arrangements that include both worker-owned and managed firms together with more traditional joint-stock firms where ownership is widely dispersed throughout society. What seemed important to Rawls is not so much specifying the combination of institutions that should constitute a POD, but rather clarifying the reasons, and elucidating the principles of justice that should inform decisions of institutional design.

Rather than discussing further the institutions of POD or their feasibility, I will now discuss how Rawls’s commitment to POD clarifies his understanding of the principles of justice and their application to social systems. Rawls regards the five social and economic systems he discusses as “ideal institutional descriptions” that incorporate certain “public aims and principles of design” (Rawls 2001, 137). The public aims and principles incorporated by property-owning democracy and liberal socialism on Rawls’s account are his own principles of justice. What are the aims and principles of welfare-state capitalism for Rawls?

Martin O’Neill, Ben Jackson, and others have questioned whether the welfare state is as different from POD as Rawls contends (O’Neill 2012; Jackson 2012). They correctly observe that many policies of a POD (universal health care,

³ See Waheed Hussain 2012 in O’Neill/Williamson (eds.), 180–200, who argues that within Rawls’s framework, workers’ co-determination rights should be just as significant as equal political liberties.

⁴ Rawls refers to Meade 1964 in *Theory* in discussing property-owning democracy (Rawls 1999a, 241–2). Meade assumed that the typical arrangement would be the corporation where workers may have some ownership interest in firms they work for, but also would own stock in many other firms.

old age pensions, unemployment insurance, a social minimum, etc.) are also integral to the welfare state. O'Neill contends that it is unclear why the welfare state could not guarantee the fair value of the political liberties or fair equality of opportunity by the institutions that Rawls mentions. The real difference between WSC and POD, he says, is that POD involves the widespread distribution of wealth, including ownership of real capital or productive resources.

It is true that Ronald Dworkin, Bruce Ackerman, and Jeremy Waldron, among others, defend versions of WSC that incorporate many institutions Rawls says are needed to guarantee the fair value of political liberties (publicly funded campaigns, etc.), as well as institutions that further fair equality of opportunity (extensive educational benefits, universal health care, steep estate taxes). Rawls does not take these more moderate forms of WSC into account, and many of his criticisms may not apply to them. Rawls seems primarily concerned with an idealization of the *capitalist* welfare state that only partly resemble these accounts and the Northern European welfare states that moderate capitalism with social democratic measures giving workers certain economic powers. Rawls seems to regard welfare state capitalism, in its pure form, as embodying the 'aims and principles' characteristic of some form of utilitarianism. I'll return to this momentarily.

But first, questions remain whether the fair value of the political liberties and FEO can be genuinely guaranteed in a capitalist welfare state that enacts campaign finance and other specific measures Rawls discusses. O'Neill correctly says that these are complicated issues of political sociology that philosophers cannot answer. But it is not unreasonable to conjecture that, so long as severe inequalities of income and wealth are allowed to endure in welfare state capitalism, these inequalities will still 'indirectly' affect election outcomes, equal access to the public political forum, and the political agenda (Rawls 2001, 139). The less advantaged are not organized like the wealthy and cannot afford specialists and lobbyists to influence or draft legislation as corporations and business-friendly non-profits do today. Nor can they afford to employ 'experts' or fund institutes that relentlessly promote the economic interests of the more advantaged on political talk shows and elsewhere. (That the least advantaged do not own and control newspapers, TV and radio stations or entire communications networks that explicitly advocate their political and economic positions goes without saying.) These inequalities enable the more advantaged to "control the course of public debate" (Rawls 1971, 225). The campaign finance measures Rawls, Dworkin, and others support address only part of the problem of the deleterious effects of vast wealth inequalities on citizens' equal access to the public political forum. *Theory* emphasizes that reducing inequalities is necessary to combat the deleterious effects of wealth on the basic liberties (Rawls 1971, 279), and to prevent concentrations of power detrimental to the fair value of political liberty. "The wide dispersal of property [...] is a necessary condition, it seems, if the fair value of the political liberties is to be maintained." (277)

Moreover, given continual conflicts between capital and labor that typify capitalism, it is questionable whether WSC can sustain the procedures of public reasoning about justice and the common good essential to Rawls's account of

property-owning democracy. For example, even though a social minimum and welfare benefits (health care, unemployment insurance, etc.) may be widely accepted in WSC, class differences between capital and labor can lead to more frequent disputes over how these benefits are to be determined and responsibilities shared than in a POD governed by a conception of reciprocity.

Similar problems stem from the influence of large wealth inequalities in connection with fair equality of opportunity. The wealthy and more advantaged who control employment have closed social networks and do not associate with the less advantaged. Moreover, in spite of efforts to equalize opportunities, there are class differences in child-rearing and socialization practices that provide enormous advantages to the more favored (Lareau 2011). Even if (as Rawls says) these differences are inevitable given the institution of the family, the effects of familial sources of inequality of opportunities are only aggravated by increasing discrepancies in income and wealth. It is a sobering fact that in the United States, which instituted measures forty years ago enabling the less advantaged to attend college (Pell Grants, subsidized loans, etc.), still only 3% of children in the top 150 colleges come from the bottom income quartile (DeBlanco 2012). These and other class-based differences provide social, educational, and employment opportunities to the more advantaged that are unavailable to the less advantaged. These inequalities of opportunities can be mitigated only by reducing the extensive inequalities of income, wealth, and economic powers that typify welfare state capitalism.

Considerations such as these may underlie Rawls's claims in *Theory* §43 that the institutions protecting fair equality of opportunity "are put in jeopardy when inequalities of wealth exceed a certain limit; and political liberty likewise tends to lose its value, and representative government to become such in appearance only" (Rawls 1971, 278). The institutional measures he discusses to support the fair value of the political liberties and fair equality of opportunity should not be assumed exhaustive or sufficient to neutralize the effects of capitalist inequalities of wealth and guarantee these basic rights. The mitigation of economic inequality even beyond what is required by the difference principle may be required.

Still, let's assume that there are forms of welfare state capitalism that can effectively incorporate many of the institutional measures Rawls associates with property-owning democracy. Rawls was surely aware of these arrangements; indeed some of the measures he mentions, though increasingly under attack since the 1980's, characterize the capitalist welfare state in the U.S. (campaign finance reforms, widespread education and job training programs, a once highly progressive tax rate on income, etc.). The reason that Rawls nonetheless presents WSC and POD as conflicting ideal institutional designs is that he regards them as incorporating different "public aims and principles of design" (Rawls 2001, 137). Welfare state capitalism is for Rawls a 'liberalism of happiness', the public aim of which is promoting individuals' happiness or welfare. Its principle of design he sees as some form of utilitarianism. Rawls often said it's not a coincidence that the great classical economists of the 19th century, the primary advocates of laissez-faire, were all utilitarians (Rawls 2008, 162). Once the adverse effects of laissez faire market distributions on the welfare of the poor, elderly and disabled

are taken into account, it is understandable why many 20th century utilitarians, including welfare economists, would advocate WSC.

To see capitalism as grounded in utilitarianism, or some form of welfarism that extolls economic efficiency, is not an unreasonable assumption.⁵ Generally arguments in support of capitalism assume that the best life for individuals is one of consumption, and that consumption is to be valued since it promotes individuals' welfare. What gets consumed must first be produced, and production depends upon economic incentives for individuals to expend efforts and take risks with the wealth at their disposal. Economic theory tells us that the motivational and informational benefits of free markets and private property in means of production outstrip any alternative system of ownership in productive efficiency and economic output. Economic output for purposes of consumption should then be maximized in a capitalist economy (Elster 1989). Add to this the preferences individuals have for freedom of contract, the liberty to use their property as they choose, and other economic freedoms, and the utilitarian/welfarist case for capitalism seems very convincing.

Rawls's contrast between POD and WSC is intended to compare the institutional embodiments of two different kinds of philosophical conceptions of justice. POD and WSC may have many of the same elements, but there still remains an important difference in the way these rights and benefits are interpreted and determined, by the 'aims and principles' implicit in the different conceptions of justice underlying these political and economic systems. The measures taken in WSC governed by utilitarianism to maintain the value of political liberties and guarantee equal opportunity and a social minimum differ in important respects from those taken by a POD governed by Rawls's two principles of justice. For example, a primary consideration in the welfare state in determining a social minimum that meets basic needs will be maximizing (restricted or weighted) welfare, whereas in property-owning democracy, it is considerations of reciprocity.⁶ That's the crucial comparison Rawls is setting up with his outline of these 'ideal institutional designs'.

For the remainder of my essay I'll discuss the primary contrasts Rawls sees between property-owning democracy and welfare state capitalism, focusing on the 'aims and principles' he sees as embodied in each—justice as fairness with the difference principle, vs. restricted utilitarianism. By 'restricted utilitarianism' Rawls means a 'mixed conception' that restricts the pursuit of social utility by recognizing equal basic liberties, equal opportunities, and a social minimum designed to meet basic needs.⁷ While non-utilitarian advocates of the welfare state, and utilitarians who support positions to the left (or right) of it, may find

⁵ David Gauthier's social contract doctrine, while not utilitarian, is still a form of welfarism with the principle of Pareto efficiency playing a predominant role. See Gauthier 1986.

⁶ In *Theory of Justice* Rawls also discusses 'mixed conceptions' that determine a social minimum by intuitive balancing of the principle of utility with an equality principle. See Rawls 1999a, 279.

⁷ John Roemer said in discussion that rather than utilitarianism, it is better to see the welfare state as grounded in a kind of prioritarianism that maximizes weighted utilities, giving greater weight to basic needs. Rawls probably would have regarded prioritarianism as a form of what he called 'restricted utilitarianism'.

Rawls's utilitarian welfare state to be a strawman, his exercise in comparison is still useful.⁸ For it highlights a significant difference between welfare state capitalism and property-owning democracy by focusing on a historically influential version of the welfare state—that of liberal economists, the vast majority of whom are utilitarians. The parallel between the development of the welfare state in the U.S. (perhaps the UK also), and welfare economics is too obvious to ignore. From this perspective the role of the welfare state within capitalism is that it increases the overall level of welfare in society by redistributions that mitigate poverty and provide all with adequate health care and other services needed for a decent life. The welfare capitalist focus on maximizing welfare while meeting basic needs provides a very different understanding of society and what it owes the less advantaged than does the idea of democratic reciprocity that informs Rawls's difference principle and his account of property-owning democracy.

4. The Difference Principle and Property Owning Democracy

Rawls contends that welfare state capitalism fails to achieve reciprocity in economic relations; also it marginalizes the least advantaged, who regard themselves as outsiders, and it undermines their sense of self-respect. In arguing for the difference principle Rawls makes similar arguments against utilitarianism. In this section I discuss three main arguments Rawls makes for the difference principle and how they support property-owning democracy.

4.1 Democratic Reciprocity

Rawls relies on several ideas of reciprocity throughout his works. He says social cooperation, unlike socially coordinated behavior, involves reciprocity: all who do their part are to benefit (Rawls 2005, 16–7). Reciprocity, Rawls also says, is a “deep psychological fact” (1999a, 433), for the sense of justice is regulated by three “reciprocity principles” that are “psychological laws” (Rawls 1971, §76, 1999a, 437–9). Moreover, public reason involves a “criterion of reciprocity”, requiring citizens to propose only those fair terms of cooperation they reasonably believe are reasonable for others to accept as free and equal citizens (Rawls 2005, 446). Finally, important for our purposes, the difference principle is said to involve “a deeper idea of reciprocity” than other alternatives, or “reciprocity at the deepest level” (Rawls 2001, 124, 49). I'll call this deeper idea ‘democratic reciprocity’.

There are two clues Rawls provides to what he means by ‘reciprocity at the deepest level’. First there is Rawls's familiar graph comparing the relative positions of the most and least advantaged groups (MAG and LAG) under the

⁸ Ben Jackson noted in discussion that Rawls relied upon James Meade's account of POD (in Meade 1964) and that Meade himself was a utilitarian. Being an economist, this comes as no surprise. Also, unlike today, there were few philosophical alternatives to utilitarianism before the 1971 publication of *A Theory of Justice*.

difference principle (= point D) vs. the principle of (average) utility (= B, the Bentham point).⁹

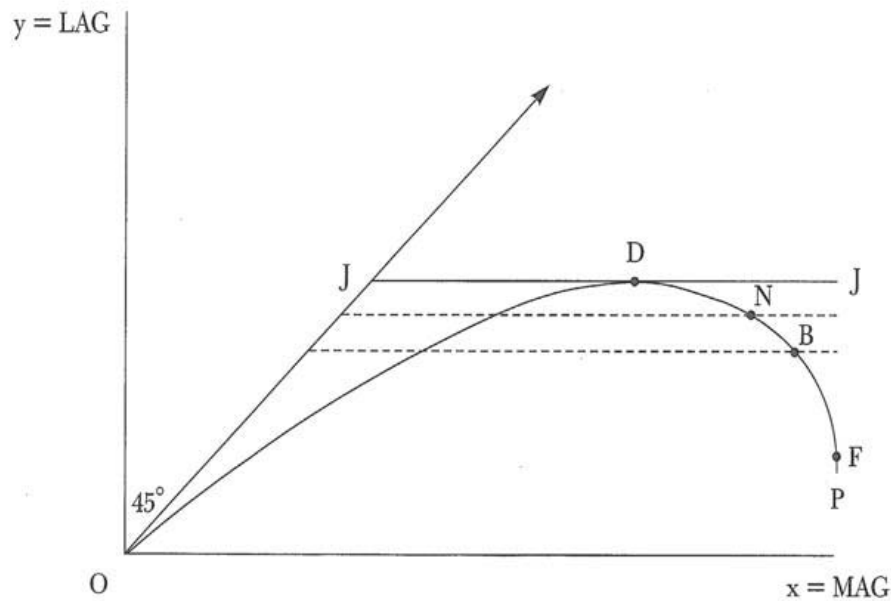

Rawls claims that reciprocity is realized when society is on the upwardly rising slope of the OP efficient production curve (O = Equality; P = Production). For at any point on the upwardly rising slope, increases in the share of primary goods going to the MAG correspond with increases for the LAG, and increases in the share of the LAG correspond with increases for the MAG. Societies should always aspire to be on the upwardly rising slope of this curve, Rawls says. *Democratic reciprocity* is achieved when society is at point D—the highest point on the efficient production curve; at this point the share going to the LAG is maximized, given current levels of technology, resources, etc. Any points to the right of D, on the downwardly sloping curve, involve further increases to the share going to the MAG that come at the expense of the less advantaged.

Rawls gives a 2d clue about what he means by ‘reciprocity at the deepest level’:

“the deeper idea of reciprocity implicit in [the difference principle] is that social institutions are not to take advantage of contingencies of native endowment, or of initial social position, or of good or bad luck over the course of a life, except in ways that benefit everyone, including the least favored. [...] This idea of reciprocity is implicit in the idea of regarding the distributions of native endowments as

⁹ Rawls 2001, 62; see also *A Theory of Justice*, §13, Figure 6.

a common asset. Parallel but not identical considerations hold for the contingencies of social position and good and bad luck.” (Rawls 2001, 124)

Why should democratic reciprocity required by the difference principle matter to the parties in the original position and to the free and equal moral persons they represent in a well-ordered society? The problem of distributive justice as Rawls defines it is the appropriate division of a social product that is the consequence not only of citizens’ cooperative efforts, but also of morally arbitrary facts. These include the distribution of natural talents by the ‘natural lottery’; the social class people are born into; and accidents of fortune and misfortune that people experience during their lives. All of these arbitrary contingencies contribute to market luck, or the economic contingencies of markets, which include the availability of productive resources, the size of the labor pool and the number of people with similar skills, the level of unemployment, and many other accidents of supply and demand affecting prices and market distributions. Given all these contingencies free and equal moral persons with a sense of justice would find it unfair and unreasonable to depart from the deeper reciprocity realized by the difference principle in distributing the benefits of economic cooperation. Rawls’s argument from democratic reciprocity resembles a contractualist argument which says that, among reasonable citizens in a well-ordered society, it would be unreasonable to reject the difference principle since that would require that we distribute the result of arbitrary contingencies (including market luck) in ways that make those with greater income and wealth better off at the expense of the least advantaged members of society. Since free and equal citizens in a well-ordered society would find this an unreasonable demand, it is not rational for the parties in the original position to prefer the principle of restricted utility or other principles to the difference principle.

Here, it is noteworthy that Rawls recognizes that there may be some other reciprocity condition that supplies appropriate standards of distribution. “We haven’t shown there is no other such condition, but it is hard to imagine what it might be.” (Rawls 2001, 124) Here some have raised the question, why should departures from equality on grounds of arbitrary contingencies be permitted at all? For Rawls, inequalities are permissible if not required by justice to call forth citizens’ greater efforts, contributions, and willingness to undertake economic risks, on the assumption that we are not impartially benevolent but have special ties and commitments, endorse a plurality of values and different conceptions of our good, and for these reasons we respond to incentives and the expectation of added advantages.

After Rawls wrote the *Restatement* (in the early 1990’s) at least two other prominent accounts of distributive justice, by Ronald Dworkin and G. A. Cohen, were developed which might be seen as raising the question: “Why wouldn’t a still *deeper* level of reciprocity be achieved if the consequences of arbitrary contingencies are strictly treated as a common asset and are equally distributed, and differences in income and wealth are permitted only as a result of individuals’ free choices?” I cannot discuss these accounts here except to raise the question

whether these and other so-called ‘luck egalitarian’ accounts are really about reciprocity at all? They seem to interpret distributive justice more as a matter of *redress* or *compensation* for misfortune than about reciprocity among equal citizens who contribute their fair share to the social product and share in the division of social benefits and burdens. Because luck egalitarians focus, not on reciprocity among socially productive citizens, but on redressing arbitrary contingencies and compensating those disadvantaged by arbitrary inequalities, they are open to the claim that distributive justice should not be contingent upon social cooperation and contributing one’s fair share but should be global in reach. Global egalitarianism, as some proponents contend, is a natural extension of luck egalitarian views (e.g., Tan 2012).

Return now to the question, why Rawls thinks that justice as fairness requires property-owning democracy rather than welfare state capitalism? A distinctive feature of Rawls’s difference principle is that it determines not simply how the social product is distributed among productive agents, but also how society is to structure ownership and divide up control of productive resources.¹⁰ This directly bears on Rawls’s argument for property-owning democracy over welfare state capitalism. The capitalist welfare state concentrates social and economic powers and positions of authority and responsibility largely in the hands of a privileged class, and regards claims of the less advantaged primarily as a matter of *compensating* them for their misfortunes and lack of income and other resources needed to satisfy their basic needs. Having a share of productive wealth and exercising economic powers and positions of responsibility are not among the basic needs of citizens in the capitalist welfare state.

In this connection, Rawls says that welfare state capitalism focuses on “the redistribution of income at the end of each period”, whereas POD “ensures the widespread ownership of productive assets and human capital (that is, education and trained skills) at the beginning of each period” (Rawls 2001, 139; also 1999a, xv).

“The intent is not simply to assist those who lose out through accident or misfortune (although that must be done), but rather to put all citizens in a position to manage their own affairs on a footing of a suitable degree of social and economic equality. [...] The least advantaged are not, if all goes well, the unfortunate and unlucky—objects of our charity and compassion, much less our pity—but those to whom reciprocity is owed as a matter of political justice. [...] Although they control fewer resources, they are doing their full share on terms recognized by all as mutually advantageous and consistent with everyone’s self-respect.” (Rawls 2001, 139)

The clear implication here is that, for purposes of the difference principle, Rawls conceives of the least advantaged as *working members* of society, or the low-

¹⁰ “A scheme of cooperation is given in large part by how its public rules organize productive activity, specify the division of labor, assign various roles to those engaged in it, and so on. These schemes include schedules of wages and salaries to be paid out of output.” (Rawls 2001, 63)

est paid and least skilled workers. The difference principle is not a principle of redress that responds to the basic needs of those who are disabled and unable or unwilling to work. Addressing individuals' basic needs for living a decent life—the driving impetus behind welfare state capitalism—is important, a 'constitutional essential' Rawls says. But he does not see addressing basic needs as a requirement of *distributive justice*. Distributive justice addresses the question of the fair distribution of the cooperatively produced social product among those who are 'fully cooperative' citizens who actively engage in productive activity and contribute their 'full share'. This clarifies a further respect in which the difference principle realizes 'reciprocity at the deepest level': it presupposes *productive reciprocity*,¹¹ that members of society contribute their full and fair share as a condition of their making distributive claims on the social product. "We are not to gain from the cooperative efforts of others without doing our fair share." (Rawls 1999a, 301)

Rawls believed that all able-bodied persons should be encouraged to work or otherwise make legitimate economic contributions. Though he endorsed income subsidies and family allowances to supplement workers' market wage, he does not regard it as appropriate to provide people with 'welfare' payments if they are able but unwilling to work. (Rawls 1999b, 455n. Rawls then rejects the idea of a basic income. See Van Parijs 1998.) By providing a social minimum for all whether they are able and willing to work or not, the welfare state can encourage dependence among the worst off, and a feeling of being left out of society. Rawls thinks that part of being an independent person is to be in a position to provide for oneself while working in employment that is not demeaning or otherwise undermines one's sense of self-respect.

This is an appropriate place to emphasize what I take to be one of the main reasons for Rawls's support for POD and liberal socialism over the welfare state. It is easy to forget that among the primary goods whose distribution is determined by the difference principle are not only income and wealth, but also powers and positions, and also the social bases of self-respect. By powers and positions Rawls means in large part economic powers and prerogatives, and offices and positions of responsibility in production. A common criticism of the capitalist wage relationship is that it leaves workers powerless in their relationships with ownership and management. They do not own capital in the firms they work for or in other firms, receive none of their firm's profits, and have no economic powers or responsibilities in the running of the firm or often even in taking initiatives in fulfilling their day-to-day responsibilities of employment. They must accept the market wage they are offered and the conditions of labor imposed upon them, however unpleasant and demeaning their work conditions might be.

To be in such a subservient position has serious consequences for worker's self-respect and their image of themselves as social equals. This is particularly true for the least advantaged, who are the least skilled and those most prone to being manipulated if not dominated, and subject to duress and arbitrary treatment. One of the primary ways that property-owning democracy differs from welfare state capitalism is that POD provides workers a share of productive capital in

¹¹ Stuart White uses this term in his contribution to O'Neill/Williamson 2012 (eds.), 129–46.

firms, as well as some degree of economic powers if not responsibilities within the firm the work in. This explains to a large degree why Rawls can argue that POD makes the least advantaged workers (the least paid and least skilled) better off than WSC, in spite of potentially greater income supplements that WSC occasionally might provide the least advantaged. (More on this later.)

4.2 The Argument From Stability

The second ground for the difference principle Rawls discusses in comparing it with (average and restricted) utility is the greater stability of a well-ordered society governed by the difference principle. Stability is also one of the main grounds Rawls later mentions in favor of property-owning democracy over the capitalist welfare state. One conception of justice is more ‘stable’ than another when it engages citizens’ sense of justice and they are more prone to comply with its demands. Rawls in later works uses the term ‘stability for the right reasons’ (Rawls 1996, xli, 390, 392). This phrase suggests that people generally accept terms of social cooperation *because* they find them reasonable and morally justifiable, and not because of a *modus vivendi* based in a contingent balance of forces. A conception of justice is stable for the right reasons when free and equal citizens all endorse it and want to comply *because* it seems reasonable in light of relevant moral/political reasons, it engages their sense of justice, *and* it is ‘congruent’ with their good and their reasonable comprehensive views.

Rawls’s arguments for the stability of a well-ordered society are largely arguments about the reasonableness of conceptions of justice from the perspective of free and equal persons in a well-ordered society who are morally motivated and want to justify themselves to one another on terms that everyone can reasonably accept.¹² Moral persons with a sense of justice in a well-ordered democratic society will not generally accept principles of justice if they find these principles place unreasonable demands on themselves, or on others. According to the reciprocity argument discussed above, it would be unreasonable for free and equal moral persons to reject the difference principle in favor of restricted utility since that would require that they distribute the result of arbitrary contingencies (including the consequences of market luck) in ways that made those with greater income and wealth better off at the expense of the least advantaged members of society. Rawls’s arguments from stability are not then simply arguments about human nature or what is rational for the interested parties to agree to in the original position to promote their good. What makes it rational (or not) to agree to a conception of justice in the original position turns in large part on whether the demands it imposes in society engages reasonable persons’ sense of justice; and the answer to this question turns on whether the conception places reasonable or unreasonable demands on citizens in a well-ordered society who seek to justify their social relations to one another on terms that respect them as free and equal citizens and as rational moral persons.

¹² This parallels T. M. Scanlon’s claim that, except for maximin, Rawls’s other arguments for the principles of justice, can be “interpreted as arguments within the form of contractualism which I have been proposing” (Scanlon 1982, 127).

Rawls makes several arguments for the greater relative stability of the difference principle over restricted utility and other ‘mixed conceptions’ that guarantee a social minimum. The difference principle encourages the cooperative virtues and mutual trust among citizens since it is publicly understood that the three main kinds of contingencies (natural talents, social class, and accidents of fortune, including market luck) will be dealt with only in ways that are to the advantage of each person. Moreover shifts in relative bargaining positions are much less likely to be exploited for self- or group-interested ends if all accept and are assured that the difference principle applies (Rawls 2001, 126). Also the difference principle relies upon easily accessible information (the least advantaged are identifiable by their share of income and wealth) and can be relatively straightforwardly applied to determine which policies are to their greatest advantage (Rawls 1999b, 229). The difference principle then resists temptations to manipulation by the more advantaged and instills greater mutual trust among citizens. Contrast this with the principle of utility; “it is much more difficult to know what maximizes average utility” (229). There are competing conceptions of utility, none of which are likely to attain general acceptance; moreover all are complex and difficult to apply in ways that elicit widespread assent. Ongoing disputes over these matters increase mistrust among individuals and groups. Moreover “the principle of utility asks more of the less advantaged than the difference principle asks of the more advantaged” (127), and asking that the less advantaged accept fewer social and economic advantages for the sake of greater benefits to the more advantaged is an extreme and unreasonable demand of them. The extreme and pervasive inequalities permitted by the principle of utility are hard to accept and put excessive “strains of commitment” on the willingness of the least advantaged to accept society’s principles of justice (Rawls 2001, 127).

Given disagreements over the interpretation and application of the principle or utility, restricted utility provides no clear public criterion for determining the social minimum. Most likely it will rely upon an idea of basic needs essential for leading a decent human life. This and other intuitive ideas in societies regulated by restricted utility will be a constant source of political dispute between the more and less advantaged, with those better off taking advantage of their greater social and political powers to manipulate public opinion and limit the social minimum. A seemingly enduring feature of capitalist societies is that the more advantaged seek to manipulate opinion and reduce the social minimum—since they feel they are saddled with the burden of paying for it—and with their superior political resources they often emerge victorious. This is a familiar feature of the welfare capitalist system in the U.S., where social programs for the poor are constantly disparaged and liable to be defunded or eliminated, and the welfare state is subject to forces that drive it back towards the laissez-faire capitalism in place before the Great Depression.

The result of continuing uncertainty and ongoing disputes about the social minimum is that the less advantaged become resentful and feel left out of sharing in society’s achievements of greater benefits. They become withdrawn and cynical about public life; rather than seeing themselves as fully members of society,

they regard themselves as outsiders who are not relevant to it. As a result they cannot fully affirm society's principles of justice (Rawls 2001, 128–30).

This last argument, which Rawls makes against the stability of restricted utility, is much the same argument Rawls makes against welfare state capitalism. Rawls says “the concept of a minimum as covering the needs essential for a decent human life is a concept for a capitalist welfare state” (129). Rawls does not reject the idea of basic needs or a decent minimum; one of the essential institutions of any liberal (if not decent) society is that it meets the basic needs of all persons in society, particularly the disabled. But satisfaction of the basic needs of the disabled is different from the reciprocity requirements of distributive justice among ‘fully cooperative’ citizens. In effect, Rawls’s objection to welfare state capitalism is that it treats the poorest members of the working classes *as if* they are disabled, for it applies to them the same standard of meeting their basic needs. If fully cooperative free and equal moral persons,

“are not to withdraw from their public world but are to consider themselves fully members of it, *the social minimum, whatever it may provide beyond essential human needs, must derive from an ideal of reciprocity* appropriate to political society so conceived. While a social minimum covering only those essential needs may suit the requirements of a capitalist welfare state, it is not sufficient for [...] a property-owning democracy in which the principles of justice are realized.” (Rawls 2001, 130, emphases added)

4.3 Publicity and Self Respect

Rawls’s claim that the least advantaged in WSC are prone to withdraw from society relates to a third argument for the difference principle, from the primary social good of self-respect. The argument from publicity and self-respect is one of the main grounds Rawls gives in *Theory* §29 for the parties’ choice of the principles of justice over average and classical utility. He argues that equal basic liberties and fair opportunities are the main social bases of self-respect, for they are institutional expressions of the freedom and equality of moral person. Moreover, the reciprocity guaranteed by the difference principle is a public expression of person’s “respect for one another in the very constitution of their society. In this way they insure their self respect” (Rawls 1999a, 156). Rawls’s claim then is that democratic reciprocity embodied in the difference principle is an expression of persons’ respect for one another, which in turn is among the bases of their self-respect. This appeal to respect leads into Rawls’s Kantian interpretation of the difference principle:

“[T]he difference principle interprets the distinction between treating men as means only and *treating them as ends in themselves*. To regard persons as ends in themselves in the basic design of society is to agree to forgo those gains that do not contribute to everyone’s expectations. By contrast, to regard persons as means is to be prepared

to impose on *those already less favored* still lower prospects of life for the sake of the higher expectations of others.” (Rawls 1999a, 157)

The principle of utility requires the less fortunate to accept lower life prospects for the sake of others who are more advantaged. “In a public utilitarian society men, particularly the least advantaged, will find it more difficult to be confident of their own worth.” (158)

Though framed to apply to a utilitarian society, this Kantian argument from respect and self-respect retains much of its force when applied to a liberal welfare state governed by restricted utility. Even though a social minimum is guaranteed, still it is determined, not by appeal to mutual respect and reciprocity, but by a conception of basic needs, weighted utilities, and greater overall welfare. In such a welfare capitalist society, citizens are more likely to regard the least advantaged as imposing social costs and burdens on others for not pulling their own weight; there is ongoing public disagreement about basic needs and the level of a decent minimum required to meet them. The least advantaged are less likely to see themselves as economically independent and as deserving of others’ respect. This aggravates their tendencies to alienate themselves from public life due to what they might see (justifiably) as public shaming by others. The damage to their self-respect, though not as severe as that caused by invidious discrimination and denial of equal liberties or fair opportunities, is still serious.¹³ This argument from self-respect favoring the difference principle over restricted utility readily applies to the comparison between POD and WSC.

The social basis of self-respect is a primary justification for POD over WSC.¹⁴ In a welfare capitalist society, where the social minimum is determined by a conventional understanding of basic needs that are to be met by *ex post* welfare payments, the least advantaged are thought of and see themselves as dependent on others’ largesse. This contrasts with property-owning democracy, where all citizens have a share of society’s capital *ex ante*, receive income from it, and (if all goes well) have no need of income supports. Productive members of the least advantaged then have more reason to see themselves as contributing their fair share to society, and as not dependent on others for income or meeting their wants and needs. Moreover, since POD also gives all productive citizens a share of economic powers and responsibilities in their employment, workers are not put in the subservient wage relationship typical of capitalism. They have a say in decisions regarding their day-to-day work activities, and representatives with a significant role in managing or policing the management of the firm. In these respects, citizens in a POD have the opportunity to exercise economic agency in addition to the political agency guaranteed by equal political rights. Both are among the social bases of self-respect.¹⁵

¹³ Joshua Cohen (1989) emphasizes the central role of the social bases of self-respect in justifying the difference principle over “mixed conceptions” that guarantee a social minimum. Rawls cites Cohen’s article, saying it is a “very full and accurate account of the difference principle” (Rawls 2001, 43 n. 3).

¹⁴ Martin O’Neill contends that the social basis of self-respect is the primary reason for Rawls’s arguments for POD over WSC (O’Neill/Williamson 2012 (eds.), 75–101).

¹⁵ Hussain 2012 and Hsieh 2012 both emphasize the central role of economic agency and workers’ enfranchisement in Rawls’s account of POD.

5. Fair Equality of Opportunity in Property Owning Democracy vs. the Welfare State

The basic aim of fair equality of opportunity (FEO) is twofold: first, to give everyone with the same talents and abilities, regardless of social background, a fair chance to compete for and achieve educational and employment positions; second, to maintain “roughly the same prospects of culture and achievement for those similarly motivated and endowed” (Rawls 2001, 44). This second aspect, the prospects of culture and achievement, does not have to be tied to the first, i.e. to fair competition for employment (so I will argue).

The primary measures Rawls discusses to achieve fair equality of opportunity include widespread educational opportunities for all (including job retraining), universal health care (Rawls 1996, 184), and the adjustment of long term trends of a market economy to prevent excessive accumulations of property and wealth that would undermine fair opportunities and lead to political domination (Rawls 2001, 44). FEO calls for limiting inequalities in income by progressive income taxes (Rawls 1971, 279), and restricting intergenerational transfers of wealth by progressive estate taxes or by inheritance taxes at the receivers end to encourage the wide dispersal of wealth. Also, FEO justifies restrictions on ‘private’ discrimination on grounds of race, gender, religion, etc., by employers and non-public educational institutions, through such measures as the 1964 Civil Rights Act in the U.S. (Rawls did not endorse ‘affirmative action’, or preferential treatment for disadvantaged minorities, except perhaps as a temporary measure in non-ideal conditions.)

Rawls claims POD differs from WSC in requiring fair equality of opportunity. While WSC goes beyond laissez-faire in requiring more than merely formal equal opportunities—by publicly funded education for all for example—Rawls says it does not go far enough. Martin O’Neill questions this argument, saying that WSC is capable of providing fair equality of opportunity, as Rawls defines it (O’Neill 2012, 84ff.). And indeed, Rawls himself earlier says that the system of ‘Liberal Equality’ guarantees fair equality of opportunity (Rawls 1971; 1999a, §12). Liberal equality resembles WSC since both endorse market efficiencies and distributions while providing a social minimum meeting the basic needs of the least advantaged.¹⁶ Moreover, many of the institutions Rawls mentions as necessary for FEO are to some degree found in existing welfare state capitalist societies. Also many welfare states, even the U.S. before the 1980’s, have steeply progressive income and estate taxes (over 75% for the top bracket in the U.S. in 1970).¹⁷ In what sense then is it *not* open to a capitalist welfare state to take its duties to the less advantaged more seriously and realize fair equality of opportunity?

¹⁶ Liberal Equality’s provision of a social minimum is not suggested in *Theory*, but is implicit in Rawls’s later claim that a constitutional essential of any liberal society is a social minimum, or “adequate all purpose means” to exercise freedoms. Rawls 1996, 228, xlvi; 1999c, 14, 49–50.

¹⁷ *New York Times*, Sunday April 15, 2012, Sunday Review, p. 6.

There are perhaps two features of Rawls's understanding of WSC that prevent it from realizing FEO in the broad sense in which he understands that idea. First, there is an egalitarian aspect of FEO that conflicts with WSC, especially when interpreted in terms of (restricted) utilitarianism or where the principle of efficiency predominates. Second, there is Rawls's association of capitalism with 'meritocratic' societies.

There is a narrow interpretation of FEO that fits with WSC, where its primary purpose is to educate individuals so that they maximize the development of their productive capacities. Individuals are to be educated commensurate with their talents and motivations in order to prepare them for fair competition for employment in the open positions arising within a free market capitalist economy. On this understanding of FEO, education benefits will be unequally distributed largely in favor of those who are naturally more talented than others, on the assumption that their talents are more worthwhile to society and justify the expense of longer education and training.¹⁸ The implication of this narrow reading is that (as Rawls says of Liberal Equality), it corrects for inequalities of social class in the competition for social positions by providing the talented similar educational opportunities regardless of social class. This does nothing, however, to compensate for the consequences of natural inequalities. Indeed, FEO narrowly construed may even aggravate the effects of unequal natural talents by generating greater social inequalities between the more and less talented.¹⁹

When Rawls discusses FEO combined with the difference principle in the position he calls 'Democratic Equality', he construes it more broadly than the narrow understanding initially set forth in conjunction with Liberal Equality. He sees FEO as imposing direct limitations on the degree of inequality in income and wealth than would otherwise be allowed by WSC, or even by the difference principle (Rawls 1971, 278–9). The institutions protected by FEO "are put in jeopardy when inequalities of wealth exceed a certain limit" (278).

Moreover, in Democratic Equality realized in POD, fair equality of opportunity should not result in pronounced inequalities of educational benefits that favor the more talented. Because of the reciprocity requirements of justice as fairness, "the priority of fair opportunity [...] means that we must appeal to the chances given to those with the lesser opportunity" (Rawls 1971, 301). Unlike the narrow role it has within Liberal Equality and welfare state capitalism, fair equality of opportunity in POD is not part of a meritocratic social system that rewards talent to promote economic efficiency over other social values (Rawls 1971, 84 and 1999a, 73). "Equality of opportunity does not mean the opportunity to leave the less fortunate behind in the personal quest for influence and social position." (Rawls 1971, 106) Instead it requires that all citizens be given greater educational and cultural benefits, regardless of their talents, so that they are able to fully develop their capacities, in order to effectively take advantage of the full range of opportunities available in society, and also to instill a sense of their self-worth.

¹⁸ See Nagel 2004, 127, who seems to interpret FEO this way.

¹⁹ Meade 1964 remarks on this effect.

“We must when necessary take into account the primary good of self respect [...] The confident sense of their own self-worth should be sought for the least favored and this limits the forms of hierarchy and the degrees of inequality that justice permits. Thus, for example, resources for education are not to be allotted solely or necessarily mainly according to their return as estimated in productive trained abilities, but also according to their worth in enriching the personal and social lives of citizens, including here the least favored. As a society progresses the latter consideration becomes increasingly more important.” (Rawls 1971, 107; 1999a, 91–2)

Unlike its narrow role in Liberal Equality and WSC, the primary aim of fair equality of opportunity in Democratic Equality and property-owning democracy is not technological advancement or encouraging a meritocracy to greater realization of productive efficiency and maximum national wealth. It is rather the egalitarian aim of guaranteeing an important social basis of self-respect for all citizens without regard to their natural abilities. When citizens are rendered unable to fully develop their capacities then those excluded are “debarred from experiencing the realization of self which comes from a skillful and devoted exercise of social duties. They would be deprived of one of the main forms of human good.” (Rawls 1971, 84; 1999a, 73)

Here again, it is notable that Rawls does not mention, in connection with Liberal Equality, that FEO requires mitigating inequalities of wealth. It is hard to see how FEO’s egalitarian requirements could apply with much force within a capitalist welfare state where distributive justice is determined by the principles of utility or efficiency with a social minimum, or even by a prioritarian account of utility that gives greater weight to the utility of the less advantaged.

To sum up, Rawls says WSC realizes fair equal opportunities to some degree, and even suggests a version of WSC, Liberal Equality, that incorporates FEO along with the principle of efficiency. But the ‘guiding aims and principles’ of WSC do not seek to limit inequalities in the primary social goods that are necessary to achieving fair equality opportunity in its full democratic sense. Just as reciprocity is not a ‘guiding aim’ of WSC, so too restricting inequalities in relevant primary social goods—income, wealth, social and economic powers—to guarantee fair equality of opportunity and the fair value of the political liberties is not a guiding aim of WSC either. Unlike welfare state capitalism, fair equal opportunity in a property-owning democracy is understood in light of the ideals of persons as free and equal and of society as grounded in democratic reciprocity and mutual respect. Having fair opportunities that put citizens in a position to develop and exercise their talents and abilities, however modest they may be, is required to maintain citizens’ equal status and self-respect as free and equal citizens who are capable of being fully cooperative over a complete lifetime. This broader reading of FEO fits with Rawls’s emphasis on the role of the Aristotelian principle in informing individuals’ rational good—his contention that it is rational for free and equal moral persons to normally prefer activities and ways of life that exercise and develop their human capacities (Rawls 1971, §65; 1999a, §65).

6. Fair Equal Opportunities to Exercise Economic Powers

Rawls says, the idea of fair equality of opportunity “is a difficult and not altogether clear idea” (Rawls 2001, 43). Now I will suggest that its lack of clarity may be a virtue since it leaves room for a still broader interpretation of FEO that allows for a third aspect, which is needed to fill a gap in Rawls’s arguments for property-owning democracy. I argue in this section that, if economic agency is to have anywhere near the importance that political agency does in Rawls’s account of property-owning democracy, then exercise of economic powers must be given greater weight than the difference principle allows (due to their potential tradeoffs with greater income and wealth). Rawls says there is no basic liberty for individuals to exercise control over means of production. So unlike the rights of political agency, economic powers necessary for economic agency cannot be guaranteed by Rawls’s first principle. The only alternative is to see economic agency as part of the fair equal opportunity principle.

The problem is this: We might conjecture the feasibility of a capitalist welfare state like Liberal Equality which enacts measures to promote to some degree fair value of the political liberties and fair equal opportunities, but without constraining inequalities of wealth. Because of wealth inequalities and incentives for the more advantaged, this capitalist welfare state is able to supply the least advantaged with income supplements and other welfare benefits that exceed the index of primary goods achievable within a property-owning democracy that provides the least advantaged with less income but a share of real capital and greater economic powers. One of the features of capitalism often cited in its favor is that it is capable of producing greater overall wealth and income than any other economic system, leaving more to redistribute in the form of welfare benefits to the less advantaged. Imagine then a welfare capitalist society that provides income supplements to the least advantaged so that their hourly wage with benefits is \$22 (= \$44,000 yearly income). Were the same society’s economy restructured as a POD, the least advantaged workers would receive \$15 per hour plus dividends from a share of society’s productive wealth for an annual income of \$36,000. It is not difficult to imagine least skilled workers in the capitalist society preferring a WSC yearly pay package of \$44,000 to the \$36,000 plus greater economic powers than they would achieve in POD. Since they are guaranteed equal basic liberties and fair opportunities anyway, the marginal damage to their self-respect that comes from receiving greater *ex post* income supplements instead of *ex ante* ownership of productive wealth and economic powers in their workplace, might seem insignificant to them—not worth the loss of \$8,000 per year in income to many of them. On these grounds it has been argued that Rawls’s contention that, under ideal conditions of a well-ordered society, POD satisfies the difference principle while WSC does not, must be mistaken. It is at least as likely that WSC will satisfy the difference principle too under ideal but feasible conditions of a well-ordered society.²⁰

²⁰ See Tomasi 2012, 226–37; also Brennan 2007, 287–99. One response to their scenario is that, because of the inequalities it allows, no form of capitalism can provide for the fair value of political liberties and fair equal opportunities. Tomasi denies this.

One way to deal with this scenario is to assign greater weight to economic powers and the social bases of self-respect in constructing the index of primary social goods. This may seem ad hoc and unconvincing to advocates of capitalism who value increased income and consumption over exercising economic powers and having a share of productive wealth. In response to a similar objection, I have argued that a way to avoid this problem that fits with Rawls's emphasis on economic agency is to regard the possession of continual opportunities to exercise economic powers and responsibilities in one's work as among the conditions of fair equality of opportunity (Freeman 2007, 135–6). Then the lexical priority of FEO over the difference principle would insulate property-owning democracy from the objection above. Even if workers might receive greater income in WSC and many prefer it to the combined index of primary goods that includes economic powers and positions of responsibility they would have in a POD, still the priority of fair equal opportunity over the difference principle requires that they not alienate their fair opportunities to exercise economic powers and responsibilities. Like the rights and powers of political agency, free and equal citizens do not have a right to alienate the powers and responsibilities of economic agency.

The suggestion then is that the principle of fair equality of opportunity requires not simply (as Rawls says) fair opportunities to compete for open positions and ongoing opportunities to take advantage of educational and cultural resources; FEO also requires ongoing opportunities for citizens to exercise economic powers and some degree of freedom and control in their work, thereby assuming a degree of initiative and responsibility. There are then several noteworthy differences between POD and WSC on this democratic interpretation of Rawls's fair equal opportunity principle. First, as mentioned earlier, unlike Liberal Equality, ongoing educational and cultural opportunities are available to all in POD without regard to their natural talents or considerations of economic efficiency. Second, the kinds of open employment positions that individuals have opportunities to compete for in POD will not be the same as those in a WSC society, like Liberal Equality, which is oriented towards economic efficiency and technocratic values. Within WSC the occupations and open positions available to members of society are largely determined by market considerations of economic efficiency and maximizing overall wealth in society. As in the U.S. currently, the positions occupied by Wall Street financiers are among the most coveted by our most talented college students. In a POD, I've argued, these positions, if they exist at all, will have a different status and rewards attached to them. The same holds for many of the other essential occupational positions that sustain the severe inequalities of a capitalist economy. Finally, unlike (welfare state) capitalism where—for reasons of maximum economic efficiency perhaps—there is no opportunity for the less advantaged to exercise economic powers and responsibilities or even to own productive wealth, the ongoing accessibility of these primary goods to everyone, including the less advantage, is an essential, perhaps the most distinctive, feature of a property-owning democracy.

What grounds are there for making this friendly amendment to Rawls's account? To begin with, for the least advantaged, like everyone else, it strengthens the social bases of self-respect to have ongoing opportunities to play an active

role and take initiatives in their workplace, and not be subject to potentially rigid work restrictions and performing the same monotonous tasks all day. Having such powers and added responsibilities mitigates the harsher aspects of the division of labor for the least advantaged in low-skilled positions. Add to this the effects of having political powers within the firm to vote for management and/or representatives on boards of directors and participate in decisions regarding work rules, and even opportunities to participate through their representatives in decisions regarding the firm's policies. Having these and other economic powers in the workplace are additional bases for self-respect that supplement those Rawls already alludes to in support of FEO, viz. continuing opportunities for educational and cultural resources to develop their capacities, including their "human capital" (Rawls 2001, 139). For less skilled workers to be able to exercise developed capacities not just in their leisure time but in their workplace as well, by overcoming the subservience of the wage relationship through the assumption of economic powers and responsibilities, can play a crucial role in providing social bases of self-respect for free and equal citizens.

Finally, there are several passages in *Theory* and *The Law of Peoples* where Rawls addresses "meaningful work" and the division of labor. Meaningful work is said to be among the "human goods" according to the Aristotelian Principle (Rawls 1999a, 373), and the opportunity for meaningful work and occupation is a condition of "citizens' self-respect [and] their sense that they are members of society and not simply caught in it" (Rawls 1999c, 50). Also, in addressing a technocratic (presumably capitalist) society that requires ever increasing wealth from one generation to the next Rawls says: "What men want is *meaningful work in free association with others*, these associations regulating their relations to one another within a framework of just basic institutions. To achieve these states of things great wealth is not necessary." (1971, 290; 1999a, 257–8, emphases added) Finally, in his discussion of the good of social union, Rawls says:

"A well-ordered society does not do away with the division of labor in the most general sense. To be sure, the worst aspects of this division can be surmounted: no one need be servilely dependent on others and made to choose between monotonous and routine occupations which are deadening to human thought and sensibility. Each can be offered a variety of tasks so that the different elements of his nature find a suitable expression. But even when work is meaningful for all, we cannot overcome, nor should we wish to, our dependence on others. [...] The division of labor is overcome not by each becoming complete in himself, but by *willing and meaningful work within a just social union of social unions in which all can freely participate as they so incline.*" (Rawls 1971, 529; 1999a, 463, emphases added)

These passages suggest that exercising one's capacities in work in a variety of meaningful tasks, and having the necessary economic powers enabling us to do so, are among the social bases of self-respect and an aspect of good of free and equal rational persons. There is room for arguing within Rawls's position that the fair equal opportunity principle provides citizens with ongoing opportunities

throughout their lifetime, not only to cultivate and exercise their powers through their work, but to have the necessary economic powers enabling them engage in meaningful work in a variety of activities.

Does this interpretation transform the fair equality of opportunity principle into a perfectionist principle? I do not think so. Rawls is not saying that meaningful work or exercising our socially productive capacities ‘in free association with others’ are necessary to self-realization and the human good. He is rather making an empirical claim supported by a ‘psychological law’, the Aristotelian Principle, about the rational life plans that would be chosen by free and equal persons in deliberative rationality. This supports the further claim that for the vast majority of individuals, meaningful work, or at least non-subservience in work, is part of their rational good if not essential to it. This is sufficient on a liberal view to justify giving everyone ongoing opportunities in their work situation to exercise economic powers and responsibilities enabling them to achieve their essential good, including their self-respect as an equal person. For those who have no interest in exercising economic powers and for whom their work means little—they’d just rather tend to their simplified assigned tasks, avoiding work whenever possible, draw their pay, and afterwards go out and enjoy it—they are not required to exercise economic powers or to participate in workers’ decisions. But even for them, not being subject to conditions of ‘wage slavery’ where their every action is monitored and regulated and they are liable to being fired for arbitrary reasons, is almost surely part of anyone’s rational good. Especially for the least advantaged workers who have few if any employment options, having some degree of latitude and freedom on the job without fear of being fired is important, and might be sufficient to make their work meaningful from their own perspective. Perhaps this is already taken care of by grounds relating to social bases of self-respect in the difference principle but it warrants reinforcement. I’m suggesting that there may be room within Rawls’s liberal principle of fair opportunities to appeal to such values as “meaningful work in free association with others” to guarantee citizens continuing opportunities across their lifetime to exercise economic powers and responsibilities. These values are realizable for *all* citizens in a property-owning democracy but not in welfare state capitalism.

7. Conclusion

Though touched upon earlier (*section 3*), I have not discussed in detail the role of the fair value of the political liberties in Rawls’s argument for property-owning democracy and against welfare state capitalism. This is necessary to fully appreciate Rawls’s predilection for POD over WSC. I’ve noted that liberal advocates of the welfare state such as Dworkin, endorse many of the measures Rawls advocates, such as campaign finance restrictions, to achieve political equality. Still, there are two aspects of Rawls’s conception of democratic government that may not be endorsable by proponents of the capitalist welfare state, particularly the utilitarian version Rawls focuses on.

First there are restrictions on inequalities of income, wealth, and economic

powers that are required in order to achieve the fair value of the political liberties. It is not clear how extensive these restrictions would need to be. Rawls says little about this crucial issue. It may be that their requirements are so stringent that any social and economic system that realized them could no longer be regarded as a form of capitalism.

Second, there is Rawls's claim that a POD based in the principles of justice will be a deliberative democracy, which involves public reasoning about laws designed to promote the common good and the fundamental interests of free and equal citizens. Rawls understood citizens' common good in terms of such values of justice as freedom, equality, the moral powers, fair opportunities, and economic reciprocity. He associated democratic capitalism with majoritarian democracy and a conflict of class interests, with little public reasoning about requirements of justice and the common good. Even if it be argued, in defense of the utilitarian capitalist welfare state, that maximizing restricted (average) utility weighted in favor of the least advantaged is the common good that democratic legislators should promote, this sort of prioritarianism is still geared towards maximizing welfare and does not guarantee democratic reciprocity and mutual respect among free and equal citizens, the fundamental grounds of Rawls's conception of a just and well-ordered property-owning democracy.

Bibliography

- Brennen, J. (2007), Rawls's Paradox, in: *Constitutional Political Economy* 18, 287–299
- Cohen, J. (1989), Democratic Equality, in: *Ethics* 99, 727–751
- Dworkin, R. (2009), *Is Democracy Possible Here?*, Princeton
- Elster, J. (1989), Self-realization in Work and Politics: The Marxist Conception of the Good Life, in: Elster, J./K. O. Moene (eds.), *Alternatives to Capitalism*, Cambridge, 127–158
- Freeman, S. (2007), *Rawls*, London
- Jackson, B. (2012), Property Owning Democracy: A Short History, in: O'Neill/Williamson (eds.), 33–52
- O'Neill, M. (2012), Free and (Fair) Markets without Capitalism, in: O'Neill/Williamson (eds.), 75–100
- (2012) (eds.), *Property Owning Democracy: Rawls and Beyond*, Chichester
- Hsieh, N. (2012), Work, Ownership, and Productive Enfranchisement, in: O'Neill/Williamson (eds.), 149–162
- Hussain, W. (2012), Nurturing the Sense of Justice: The Rawlsian Argument for Democratic Corporatism, in: O'Neill/Williamson (eds.), 180–200
- Lareau, A. (2011), *Unequal Childhoods*, revised edition, Berkeley–Los Angeles
- Meade, J. (1964), *Efficiency, Equality, and the Ownership of Property*, London
- Nagel, T. (2004), *Concealment and Exposure*, Oxford
- Rawls, J. (1971), *A Theory of Justice*, Cambridge/MA
- (1996), *Political Liberalism*, Cambridge/MA
- (1999a), *A Theory of Justice*, revised edition, Cambridge/MA
- (1999b), *Collected Papers*, S. Freeman (ed.), Cambridge/MA
- (1999c), *The Law of Peoples*, Cambridge/MA
- (2001), *Justice as Fairness: A Restatement*, E. Kelly (ed.), Cambridge/MA

- (2008) *Lectures on the History of Political Philosophy*, S. Freeman (ed.), Cambridge/MA
- Roemer, J. (1994) *A Future for Socialism*, Cambridge/MA
- Scanlon, T. M. (1982), Contractualism and Utilitarianism, in: Sen, A./B. Williams (eds.), *Utilitarianism and Beyond*, Cambridge
- Tan, K. C. (2012), *Justice, Institutions, and Luck*, Oxford
- Tomasi, J. (2012), *Free Market Fairness*, Princeton
- Van Parijs, P. (1998), *Real Freedom for All*, Oxford